

Fw 190A-5

eduard

GERMAN WWII FIGHTER

1/72 SCALE PLASTIC KIT

ProfiPACK
edition

#70116



INTRO

The second half of the Second World War saw the Focke-Wulf Fw190, in its various forms, emerge as the best of what was available to the Luftwaffe. The dedicated fighter version was a high performance, heavily armed machine. Its development had a precarious beginning, against a 1938 specification issued by the Technisches Amt, RLM. The first prototype took to the air on June 1, 1939. After a series of improvements and even radical changes, the design culminated in the fall of 1940 in the pre-series version Fw190A-0 to the tune of twenty-eight pieces. Six of these were retained by the test unit Erprobungsstaffel 190 at Rechlin, which was tasked with conducting service trials. These revealed a wide range of flaws to the point where the RLM halted further development. Despite this, on the basis of urgings from the test unit staff, the aircraft was not shelved. After a series of some fifty modifications, the RLM gave the go ahead for the Fw 190 to be taken into inventory of the Luftwaffe. In June 1941, the Luftwaffe accepted the first of 100 ordered Fw 190A-1s, armed with four 7.9 mm MG17s. By September 1941, II/JG 26 was completely equipped with the type, operating on the Western Front. November saw the production of the next version Fw 190A-2, powered by a BMW 801C-2, and armed with two 7.9mm MG17s and two MG151s of 20mm caliber in the wings. Part of this series received an additional pair of 20mm MG FFs, thus attaining an armament standard of later types. A significant advancement to the design came in the spring of 1942, when the BMW 801D-2 became available, whose installation gave birth to the Fw 190A-3. July saw the development of the improved A-4. Both were armed with what became the standard two fuselage mounted MG17s, two wing mounted MG 151 cannon, and two MG FF cannon, placed inboard of the wheel wells. During 1942, production had intensified, and a production facility was set up under license at Fieseler. Thanks in part to this, production rose in 1942 to 1,878 units as opposed to 224 in 1941. Large-scale production of the A-5 was initiated in April 1943, with an identical wing to the A-4, but with a nose extension that would become standard on all subsequent Fw 190A versions up to the A-9, and also on the corresponding F types. July saw the development of a new, strengthened wing, which incorporated MG151s instead of the MG FFs in the outer position. The adoption of this wing developed the A-6 version. Further changes developed the A-7, produced during the end of 1943. This version came about with the replacement of the fuselage mounted MG 17s with 13mm MG 131s. Further improvements led to the Fw190A-8, and this version became the most widely produced with some 1400 units made. The most significant change to this variant was the installation of the GM-1 nitrous-oxide injection system, for temporary power boost in combat. A portion of A-8 production was built as the A-8/R2 and A-8/R8, armed with MK 108 cannon in the outer wing location, and with armoured slabs added to the cockpit sides and a modified canopy. The final production version of the BMW 801 powered fighter was the Fw 190A-9, equipped with the BMW 801TS of 2000hp (1470kW). There was a parallel development of these fighter optimized aircraft with a dedicated fighter-bomber version, the Fw 190F. These aircraft had reduced wing armament to two MG 151 cannon in the wingroot position. The engine was optimized for low level operation, and the armament options varied to satisfy the ground attack role, including bombs of various weight classes and a variety of anti-tank rockets. This branched into the extended range Fw 190G version. Development of the thoroughbred fighter continued in the guise of the Fw 190D, which began to reach Luftwaffe units in the second half of 1944, and was the result of mounting an in-line Jumo 213A-1 engine into a modified Fw 190A-8 airframe. Although the Fw 190 never achieved the widespread usage of the competing Bf 109, its contribution to the German Air Force was certainly significant through the second half of WWII. Fw 190s saw service on the Western Front as well as in the East. As heavy fighters with imposing firepower, they found themselves integral components, from 1943 onwards, within the units tasked with the protection of the Reich from the ominous clouds of allied four-engine bombers. This is where the A-8 version was instrumental, along with its A-8/R2 armoured development. This version, with its firepower, was a very ominous and daunting foe for the bomber crews. From the second half of 1944, their danger was kept in check to a degree by escorting P-47s, and necessitated the development of the P-51 Mustang.

ATTENTION



UPOZORNĚNÍ



ACHTUNG



ATTENTION



注意



Carefully read instruction sheet before assembling. When you use glue or paint, do not use near open flame and use in well ventilated room. Keep out of reach of small children. Children must not be allowed to suck any part, or pull vinyl bag over the head.



Před započatím stavby si pečlivě prostudujte stavební návod. Při používání barev a lepidel pracujte v dobře větrané místnosti. Lepidla ani barvy nepoužívejte v blízkosti otevřeného ohně. Model není určen malým dětem, mohlo by dojít k požití drobných dílů.

INSTRUCTION SIGNS * INSTR. SYMBOLS * INSTRUKTION SINNBILDEN * SYMBOLES * 記号の説明

OPTIONAL
VOLBABEND
OHNOUTOPEN HOLE
VYVRTAT OTVORSYMMETRICAL ASSEMBLY
SYMETRICKÁ MONTÁŽNOTCH
ZÁŘEZREMOVE
ODŘÍZNOUTAPPLY EDUARD MASK
AND PAINT
POUŽIT EDUARDS MASK
NABARVIT

PARTS



DÍLY



TEILE



PIÈCES



部品

PLASTIC PARTS

A>

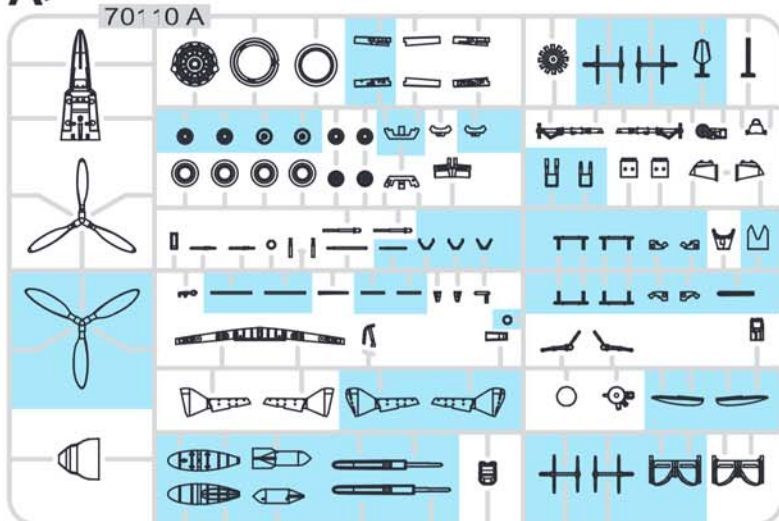

D>

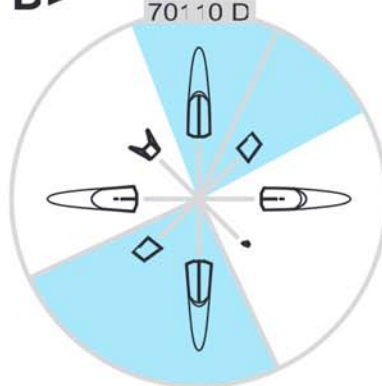

J>

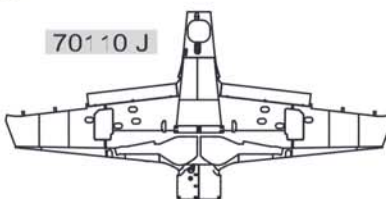

G>

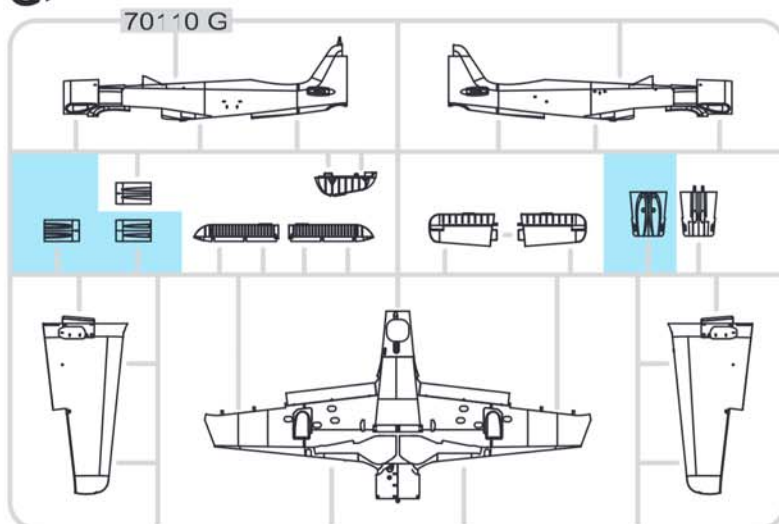
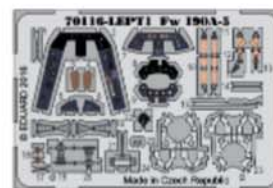
PE - PHOTO ETCHED
DETAIL PARTSeduard
MASK

Parts not for use - Teile werden nicht verwendet - Pièces à ne pas utiliser - Tyto díly nepoužívejte při stavbě - 使用しない部品

COLOURS



BARVY



FARBEN



PEINTURE



色

GSI Creos (GUNZE)			
AQUEOUS	Mr.COLOR		
H2	C2	BLACK	
H11	C62	FLAT WHITE	
H12	C33	FLAT BLACK	
H33	C81	RUSSET	
H47	C41	RED BROWN	
H64	C17	DARK GREEN	RLM71
H65	C18	BLACK GREEN	RLM70
H68	C36	DARK GRAY	RLM74
H69	C37	GRAY	RLM75
H70	C60	GRAY	RLM02

AQUEOUS	Mr.COLOR		
H77	C137	TIRE BLACK	
H111	C113	YELLOW	RLM04
H114	C114	RED	RLM23
H116	C116	BLACK GRAY	RLM66
H117	C117	LIGHT BLUE	RLM76
Mr.COLOR SUPER METALLIC			
SM06		CHROME SILVER	
Mr.METAL COLOR			
MC21R		STAINLESS	
MC21B		DARK IRON	

**IF YOU USE PARTS PE2 AND PE7,
THEN YOU MUST USE PARTS A7 AND A8.**

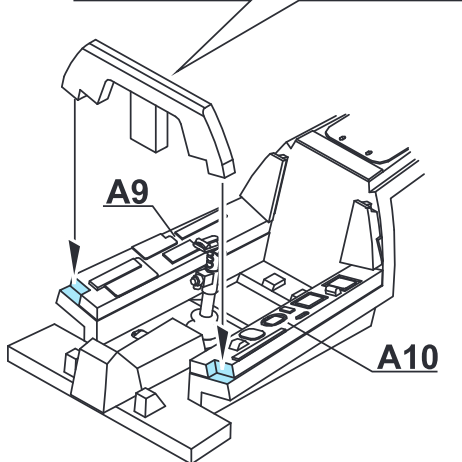
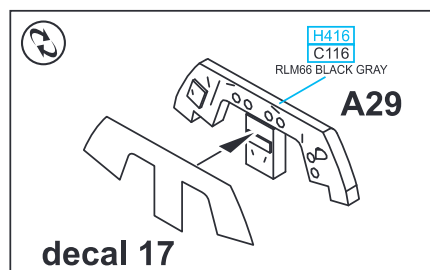
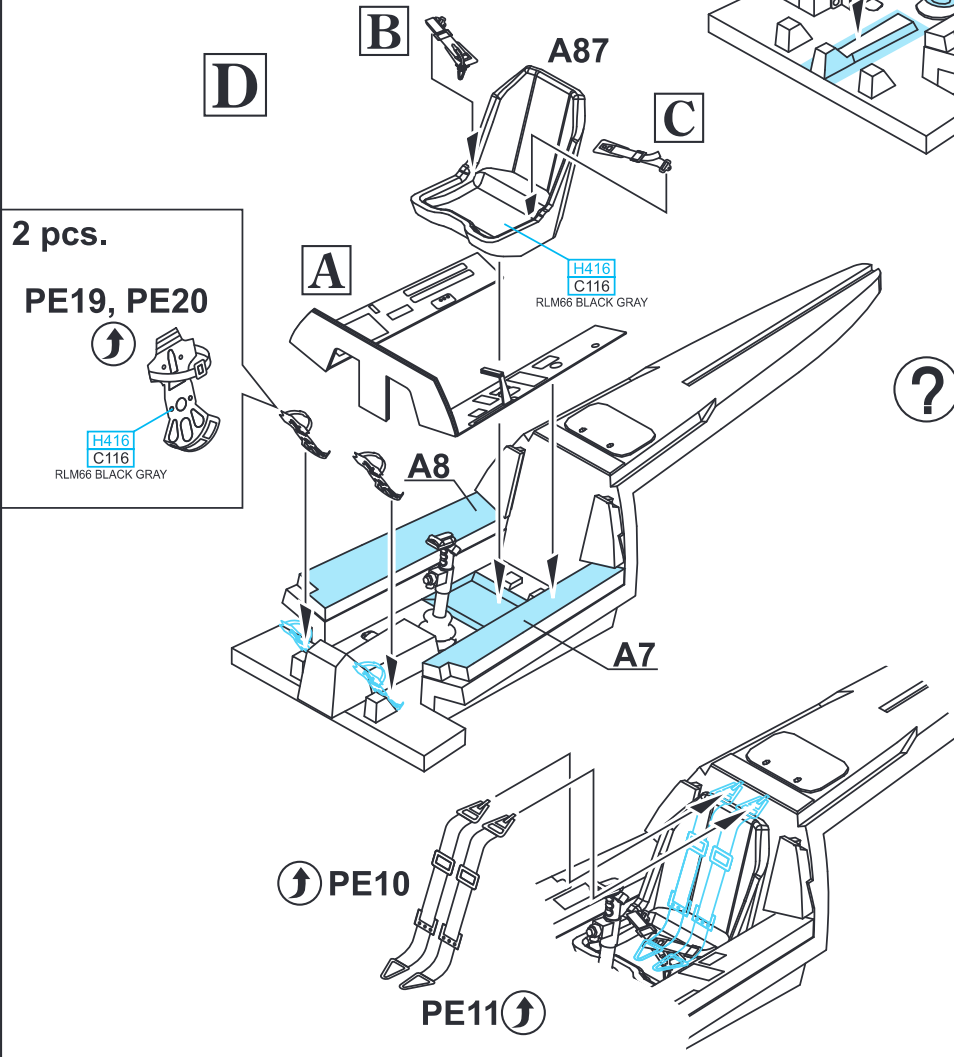
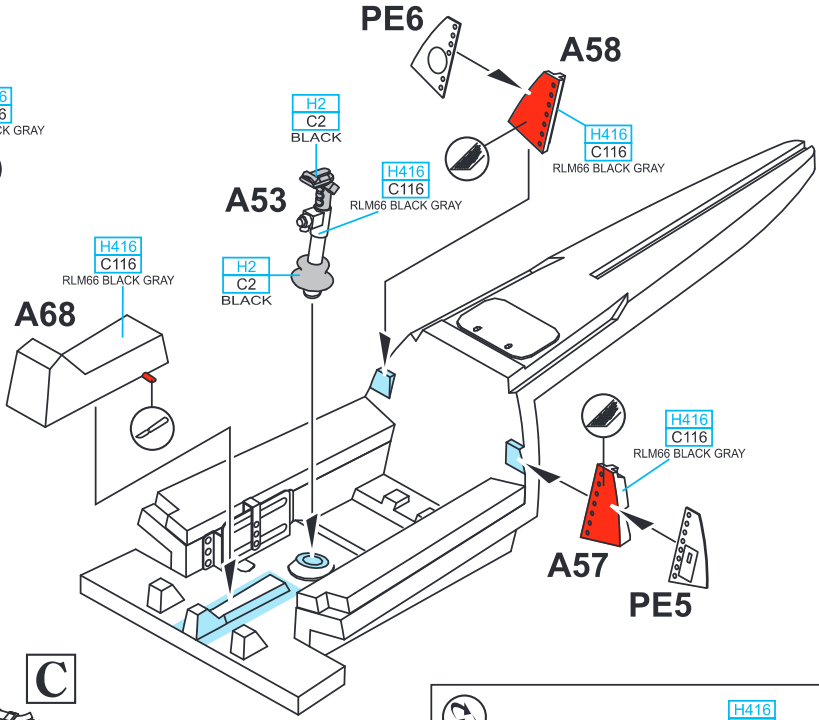
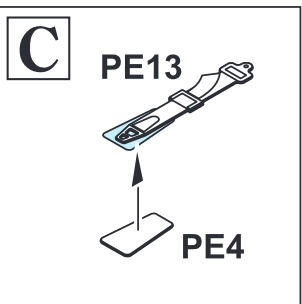
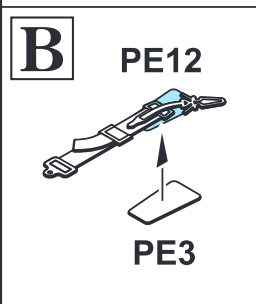
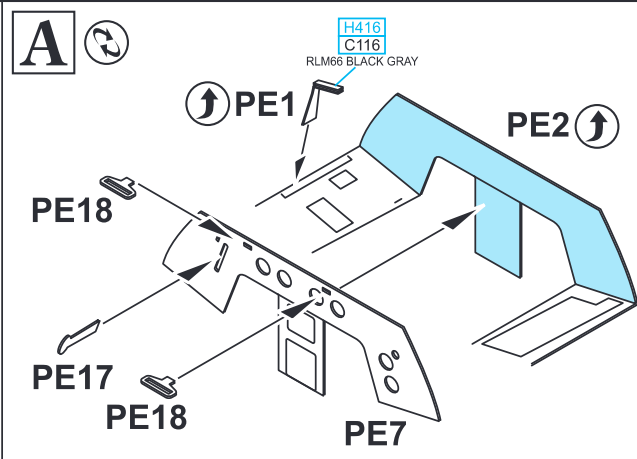
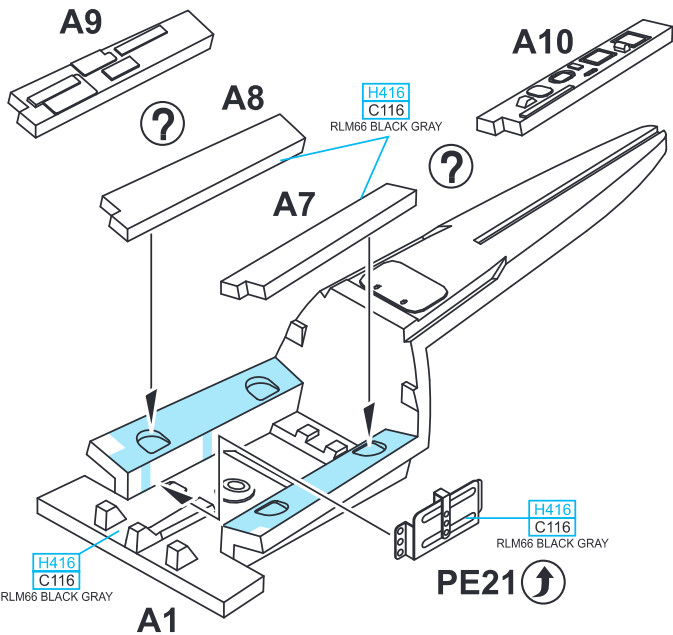

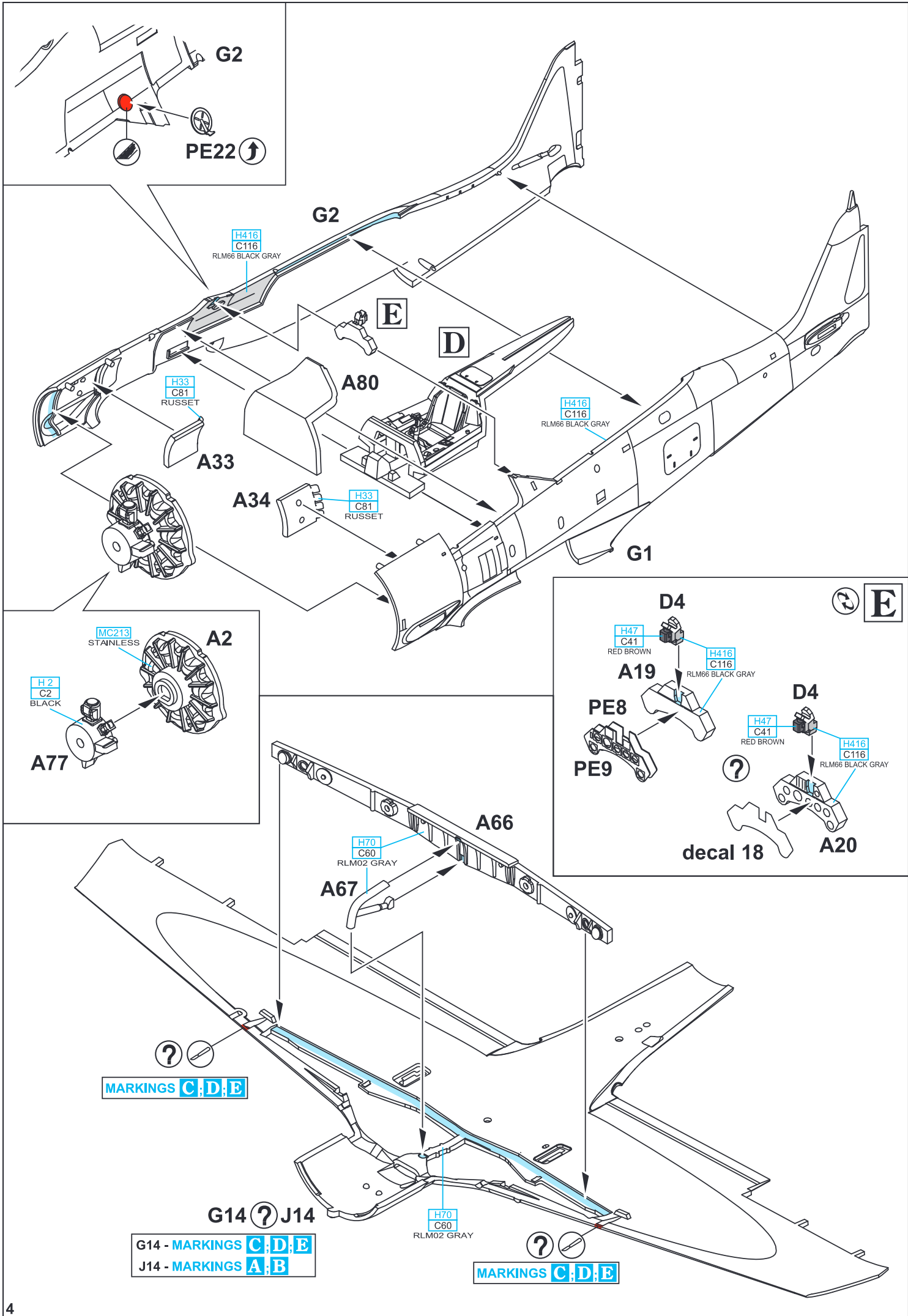

G2

PE22 ↕

H416
C116
RLM66 BLACK GRAY

E

D

H33
C81
RUSSET

A33

A80

H416
C116
RLM66 BLACK GRAY

A34

H33
C81
RUSSET

G1

MC213
STAINLESS

A2

H2
C2
BLACK

A77

E

D4

H47
C41
RED BROWN

A19

H416
C116
RLM66 BLACK GRAY

PE8

PE9

?

H47
C41
RED BROWN

D4

H416
C116
RLM66 BLACK GRAY

decal 18

A20

A66

H70
C60
RLM02 GRAY

A67

?

MARKINGS C;D;E

G14 ? J14

G14 - MARKINGS C;D;E
J14 - MARKINGS A;B

H70
C60
RLM02 GRAY

?

MARKINGS C;D;E

PE24 ↕ ↔ PE25

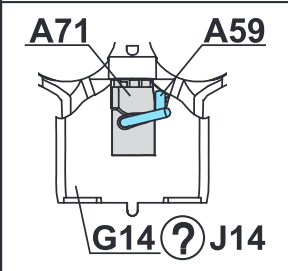
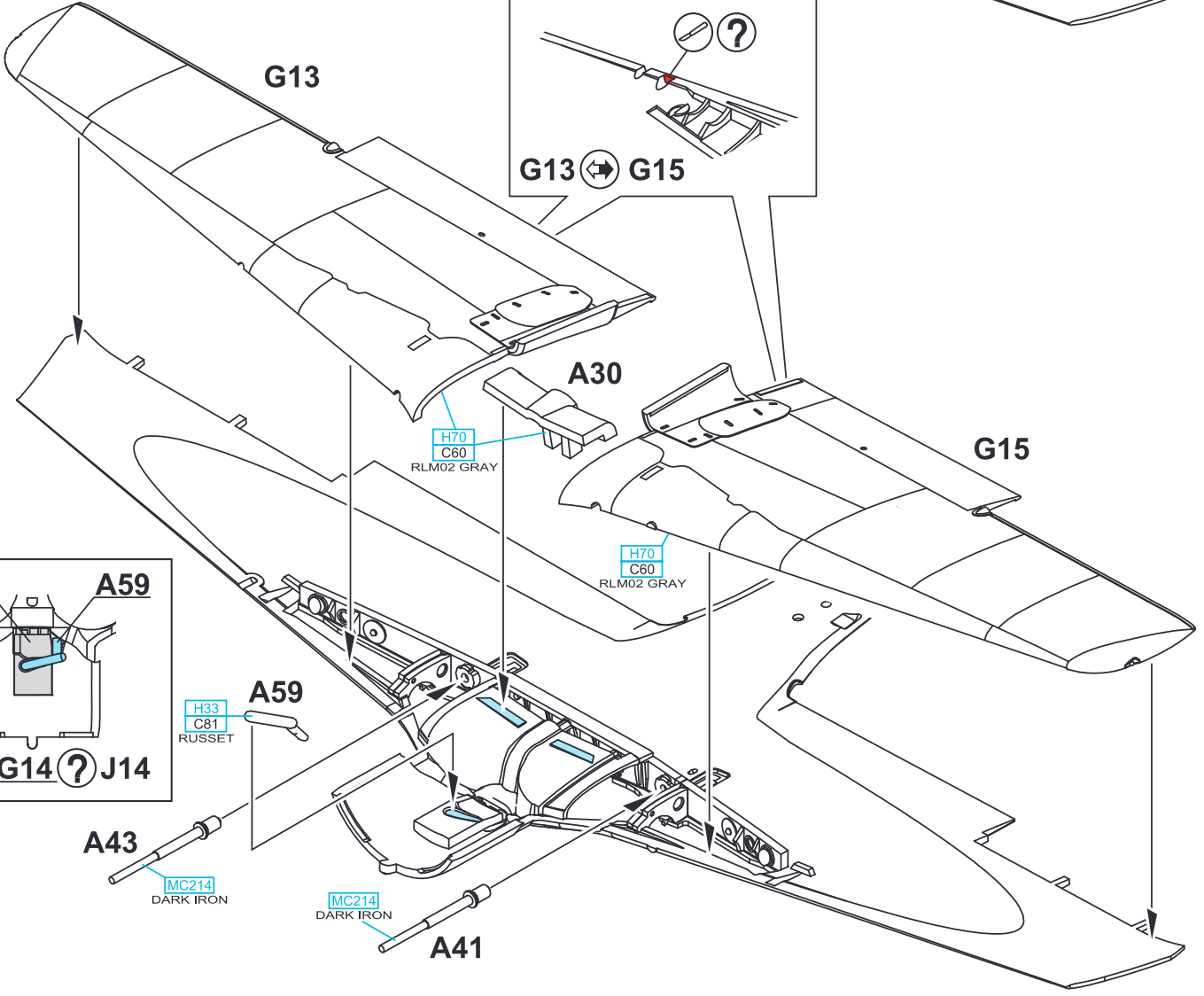
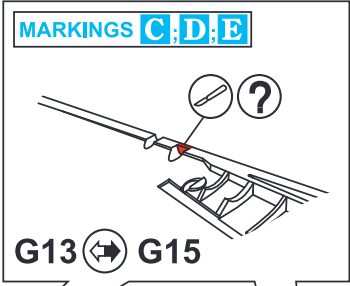
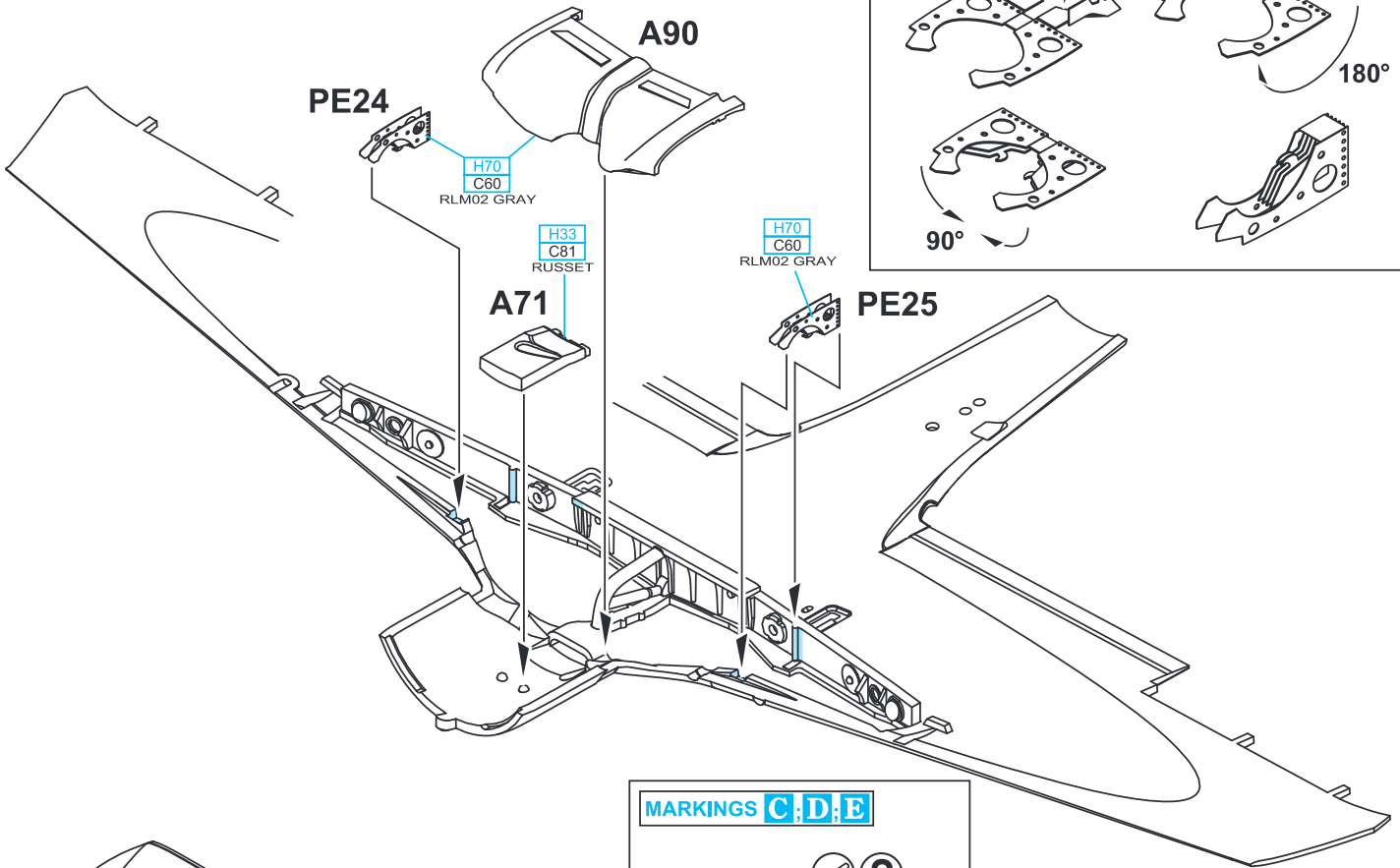
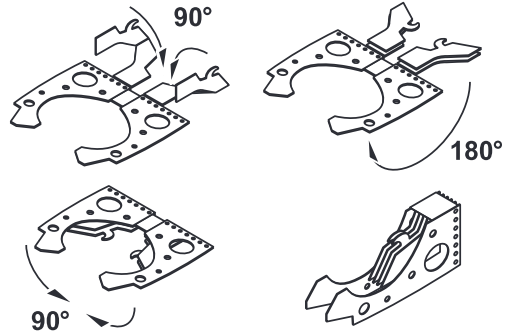

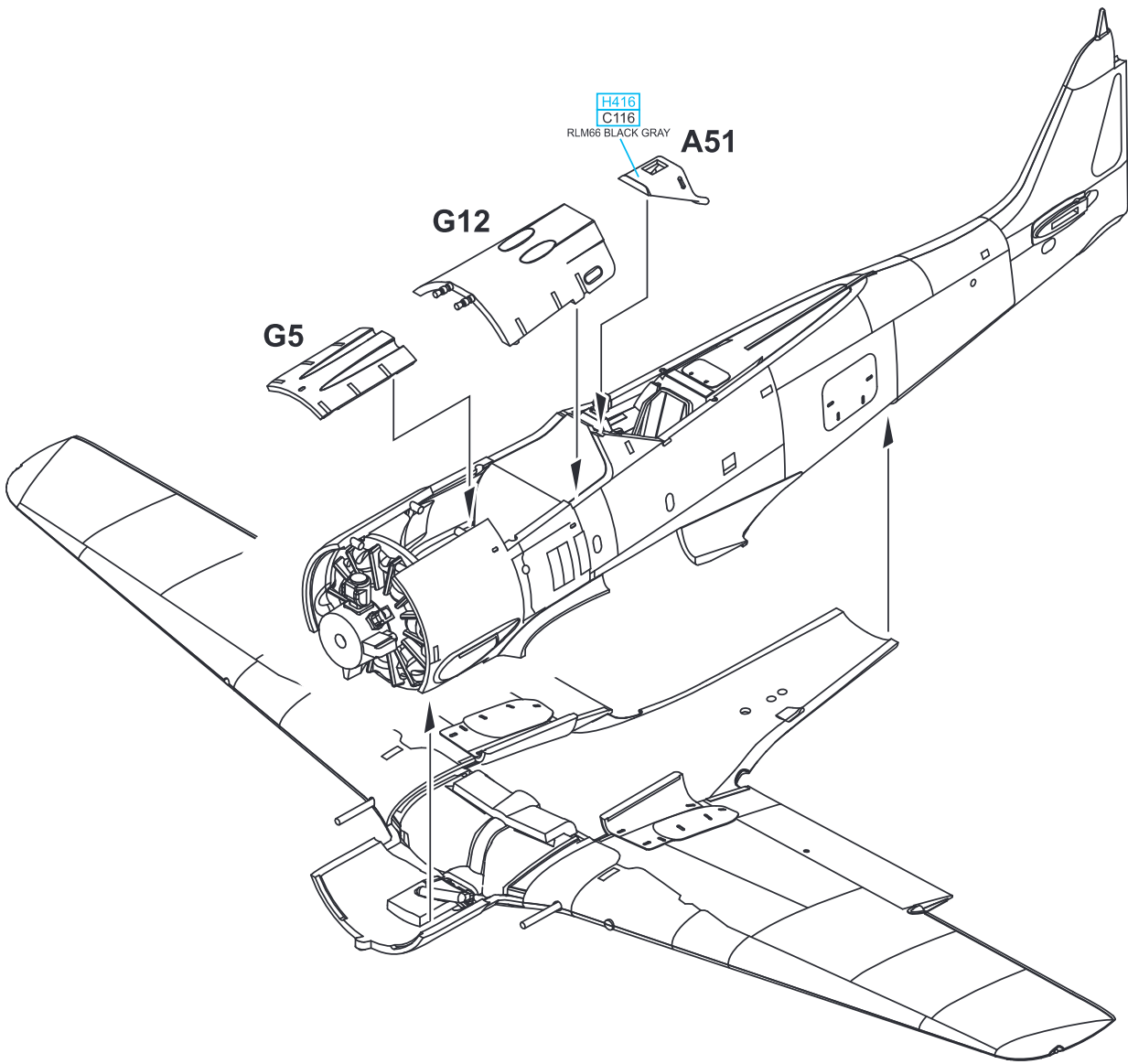

H416
C116
RLM66 BLACK GRAY

A51

G12

G5

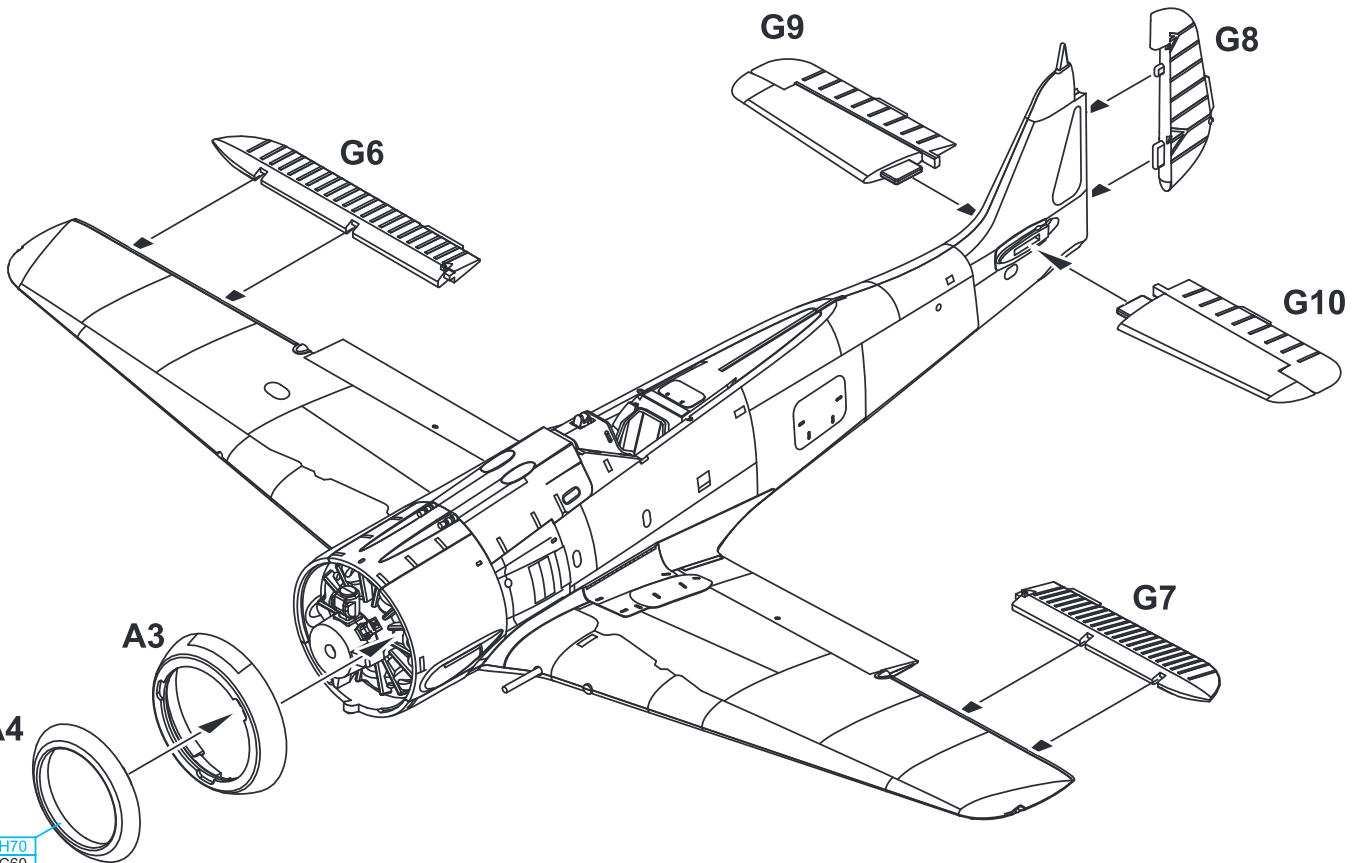

G9

G8

G6

G10

G7

A3

A4

H70
C60
RLM02 GRAY

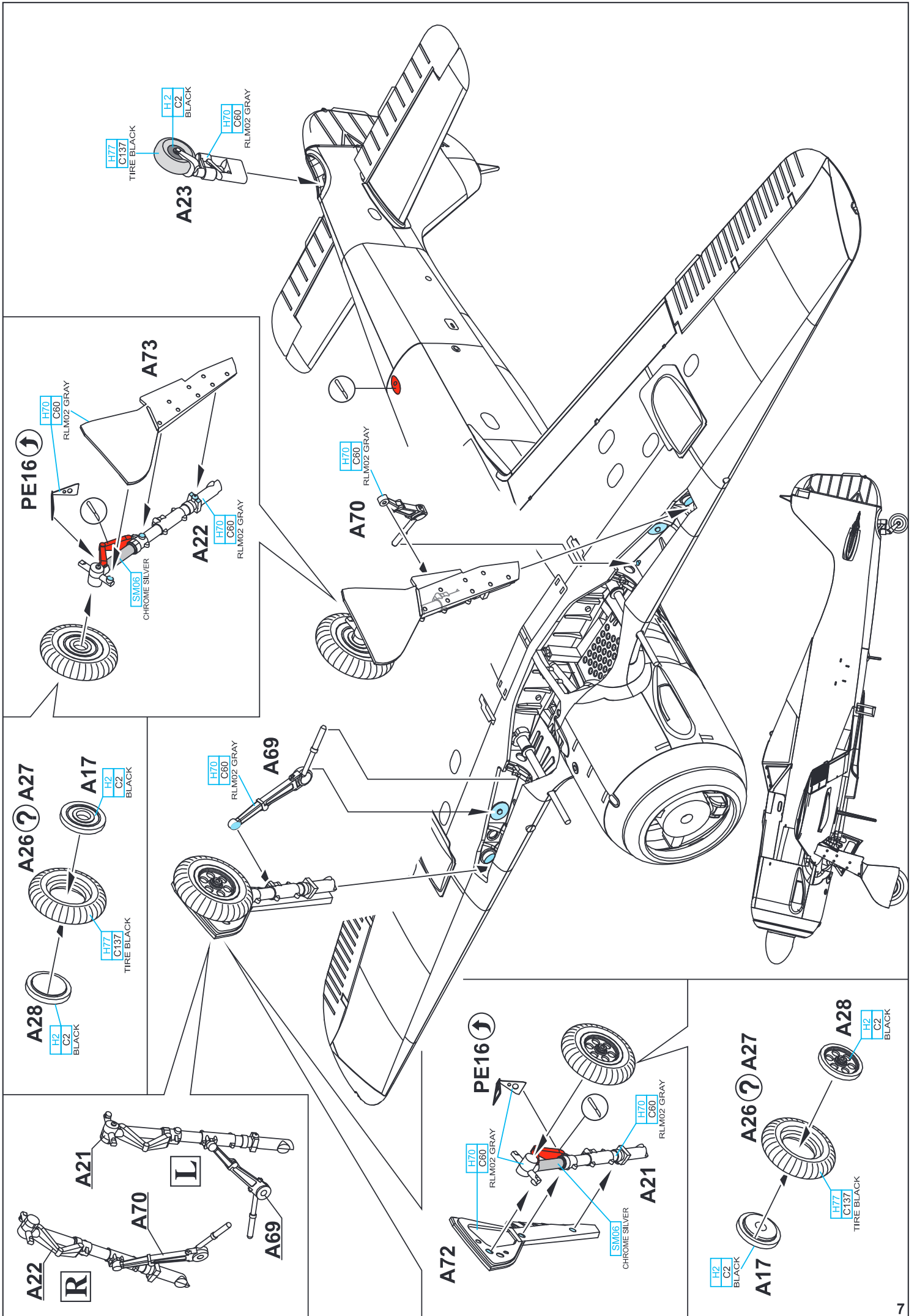

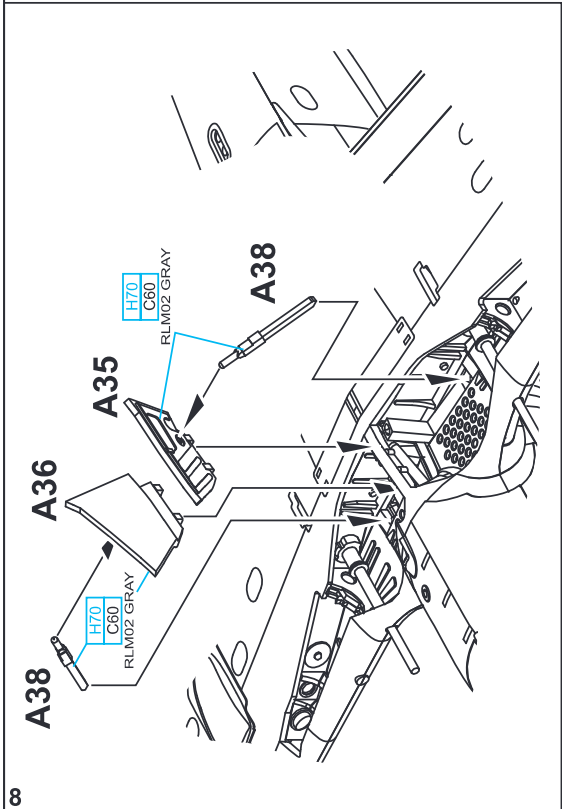

PE14, PE23 - MARKING E ONLY

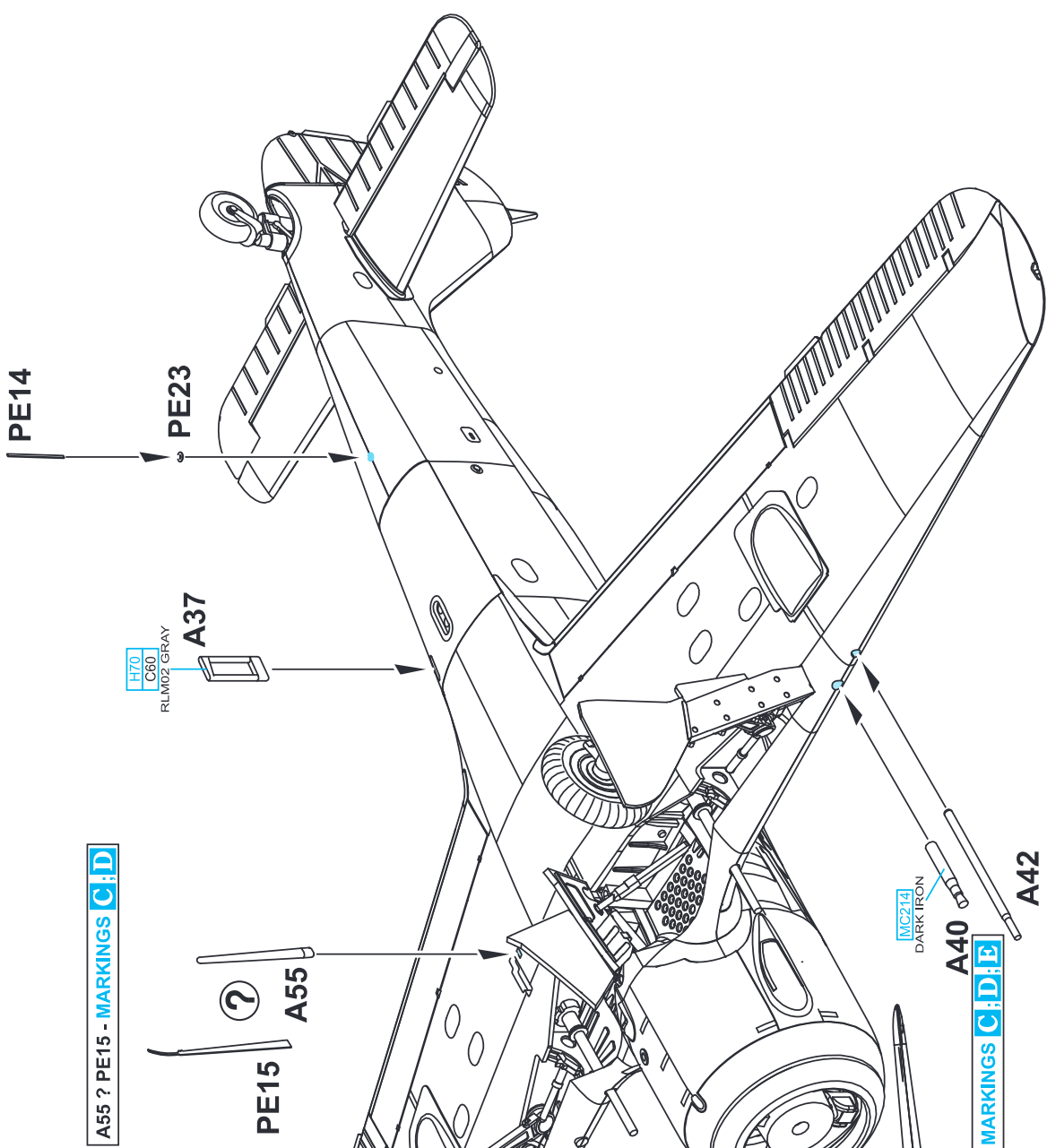

A55 ? PE15 - MARKINGS C; D

A40 - MARKINGS C; D; E

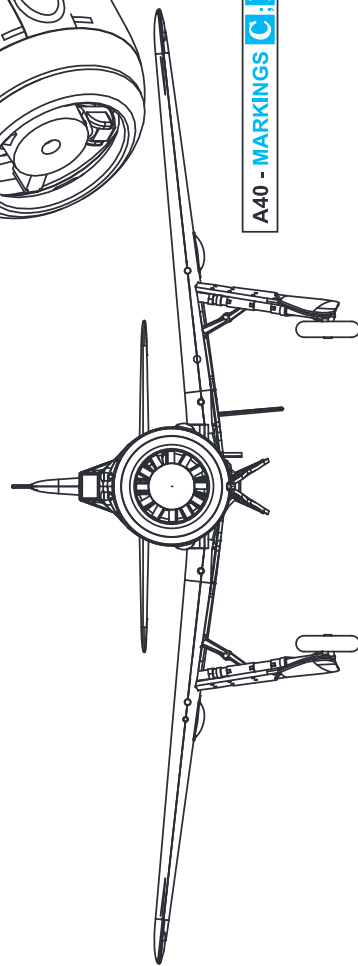

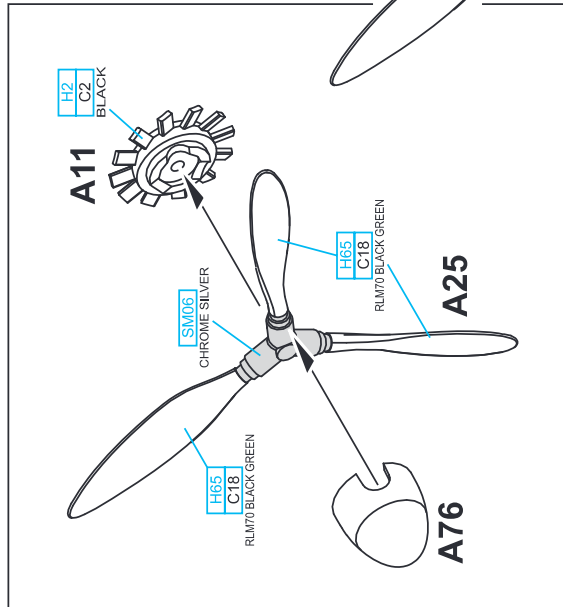
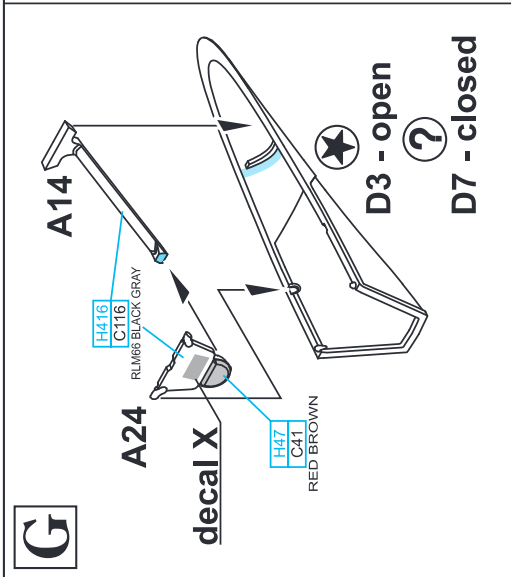
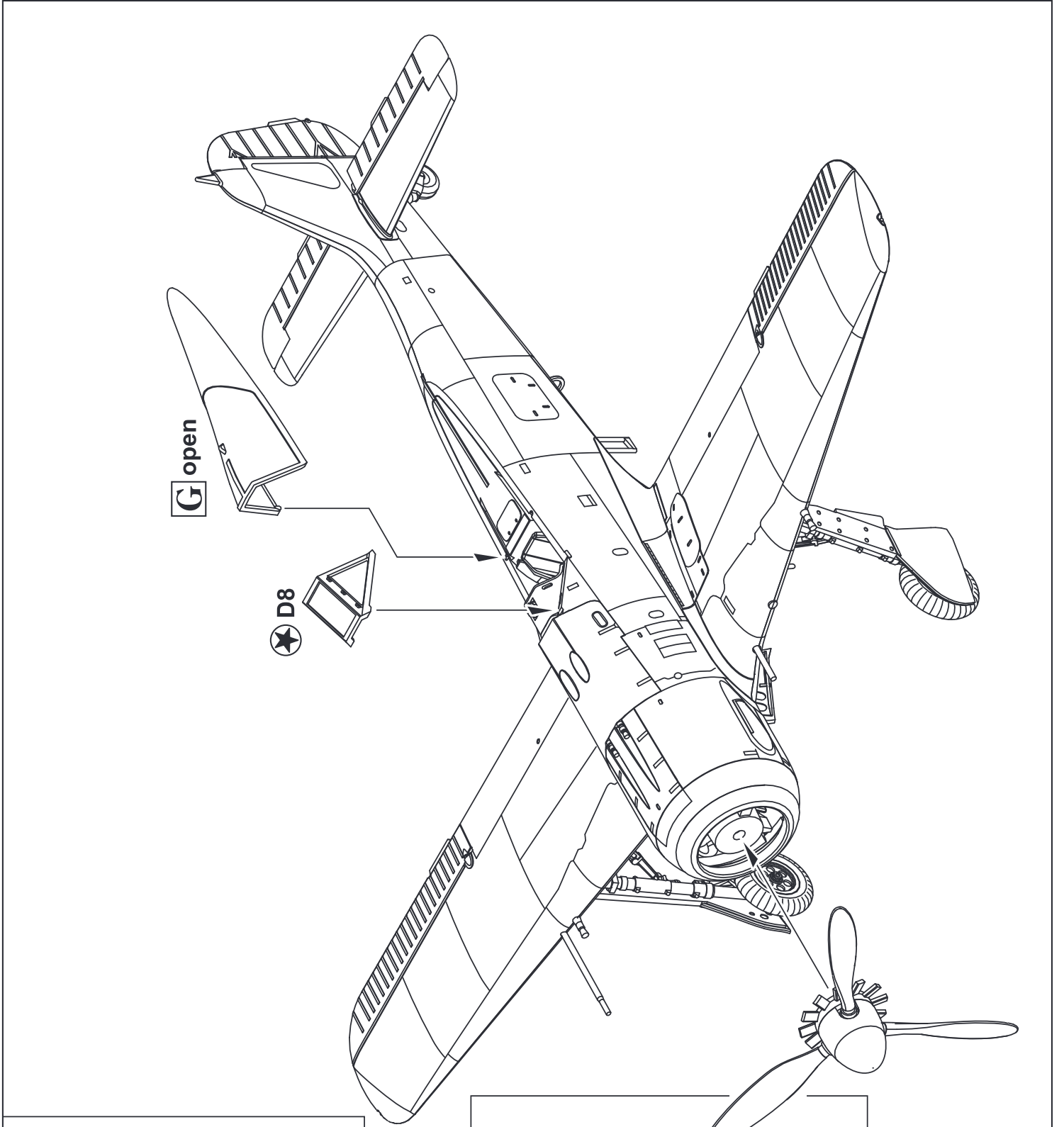

70116

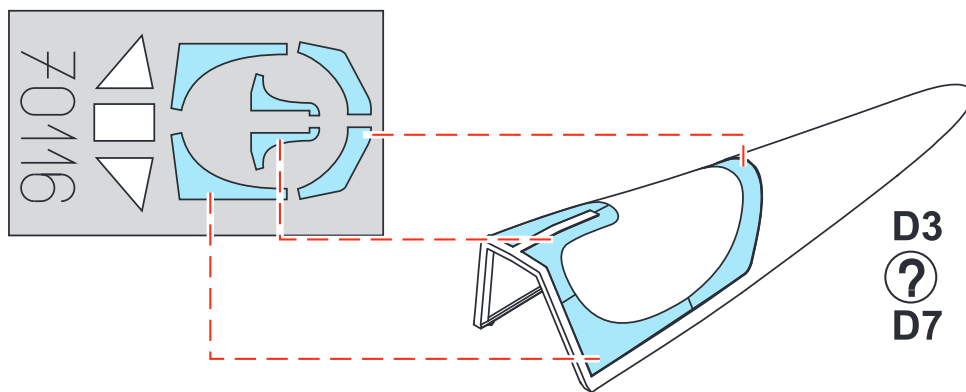
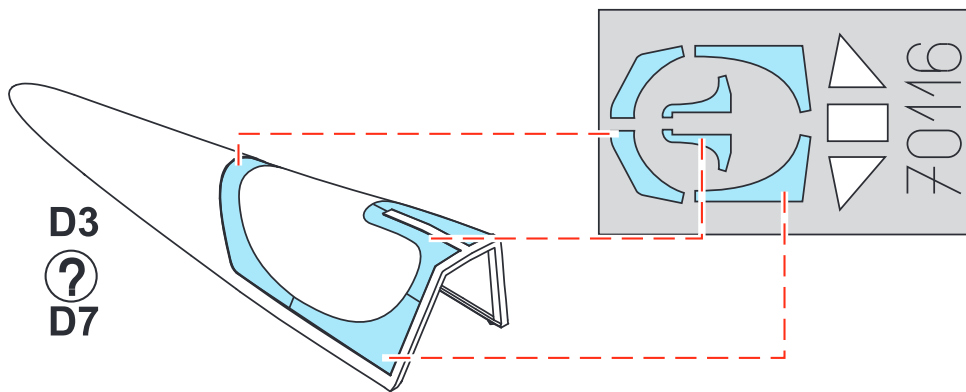
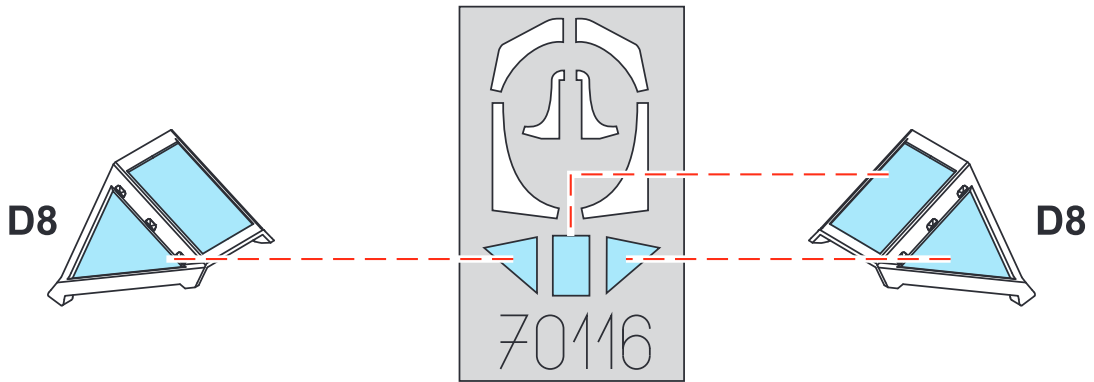

A W.Nr. 2594, Maj. Hermann Graf, CO of JGr Ost, Bordeaux, France, Spring 1943

Hermann Graf was credited with 212 kills, 202 of them over the Eastern Front. He was awarded the Knight Cross with Oak Leaves, Swords and Diamonds on September 16, 1942 for 172 kills. Graf flew this colorful aircraft in the spring of 1943 when he served as the CO of Jagdgruppe Ost, a training unit. The unit crest – a bird teaching fledglings – is painted on the right side of the fuselage. The numeral on the rudder represents Graf's score. He would add ten more while serving with JGr 50 and JG 11. The appearance of this aircraft gradually changed and even included the U7 kit.

ČESKOU VERZI TEXTU NALEZNETE NA www.eduard.com/s/70116

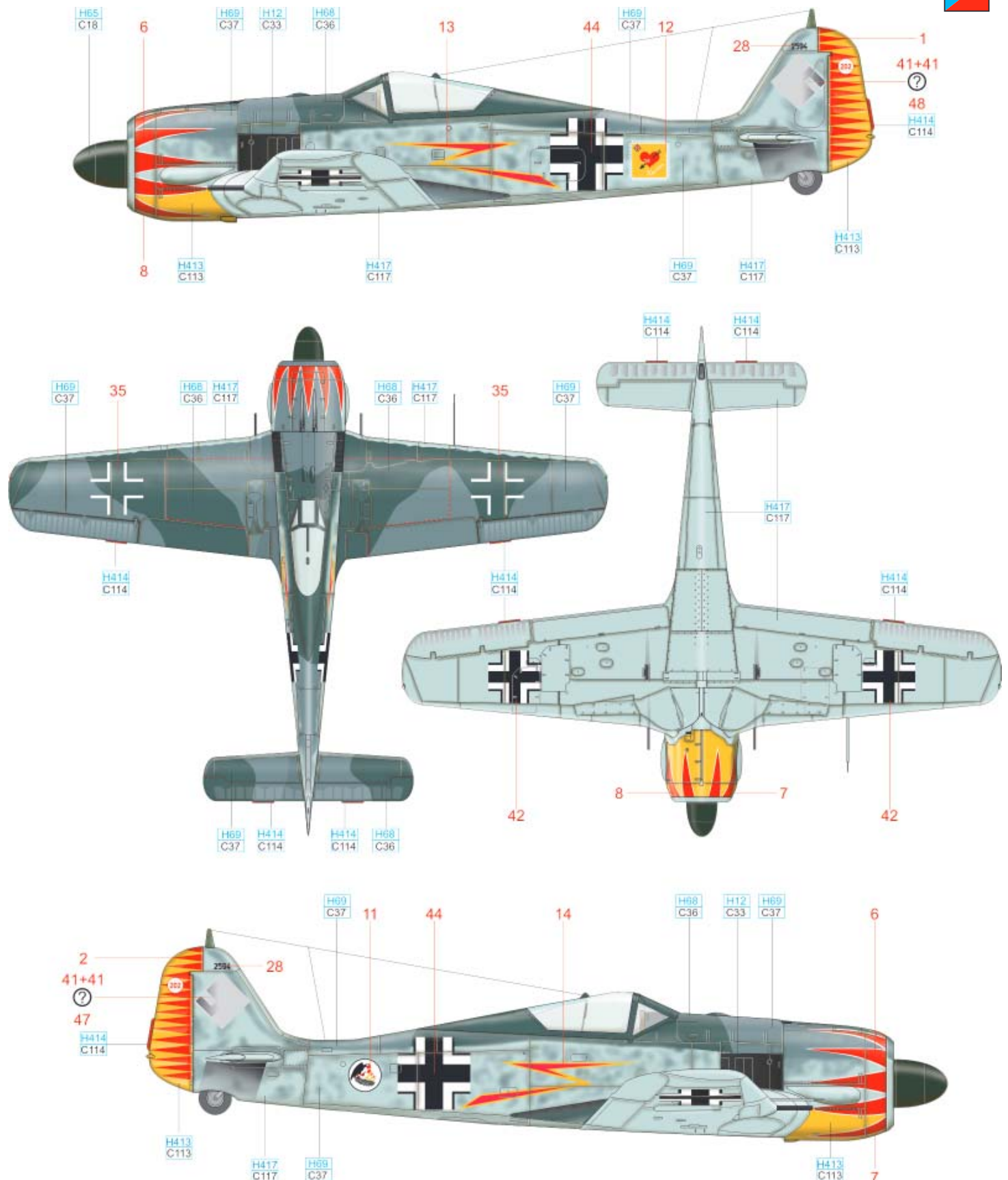

RLM 23	H414 C114	WHITE	H11 C62	BLACK	H12 C33	RLM 04	H413 C113
RLM 76	H417 C117	RLM 75	H69 C37	RLM 74	H68 C36	RLM 70	H65 C18

B Hptm. Walter Nowotny, CO of I./JG 54 Grünherz, Orel, Fall 1943

An Austrian, Walter Nowotny, joined JG54 in 1941. He commanded the 1st Staffel from October, 1942, and in August of 1943 was nominated to command I./JG 54. He achieved 256 aerial victories on the Eastern Front, with another 20 unconfirmed. From early 1944, he commanded JG 101, a training unit in France. In September 1944, he was tasked with forming Erprobungskommando Nowotny (III./JG 6), a test unit equipped with the new Me 262 jet fighters. Flying an Me 262, he was killed in action on November 8th, 1944. He flew 442 combat missions, and was awarded the Knight's Cross with Oak Leaves, Swords and Diamonds. Flying this aircraft, Oblt. Otto Vincent, commander of 2./JG 54, went missing in action on January 4th, 1944, after combat with Il-2s. The aircraft wore an unusual upper wing camouflage, seen on some of the aircraft produced by the AGO works plant in Oschersleben.

ČESKOU VERZI TEXTU NALEZNETE NA
www.eduard.com/s/70116

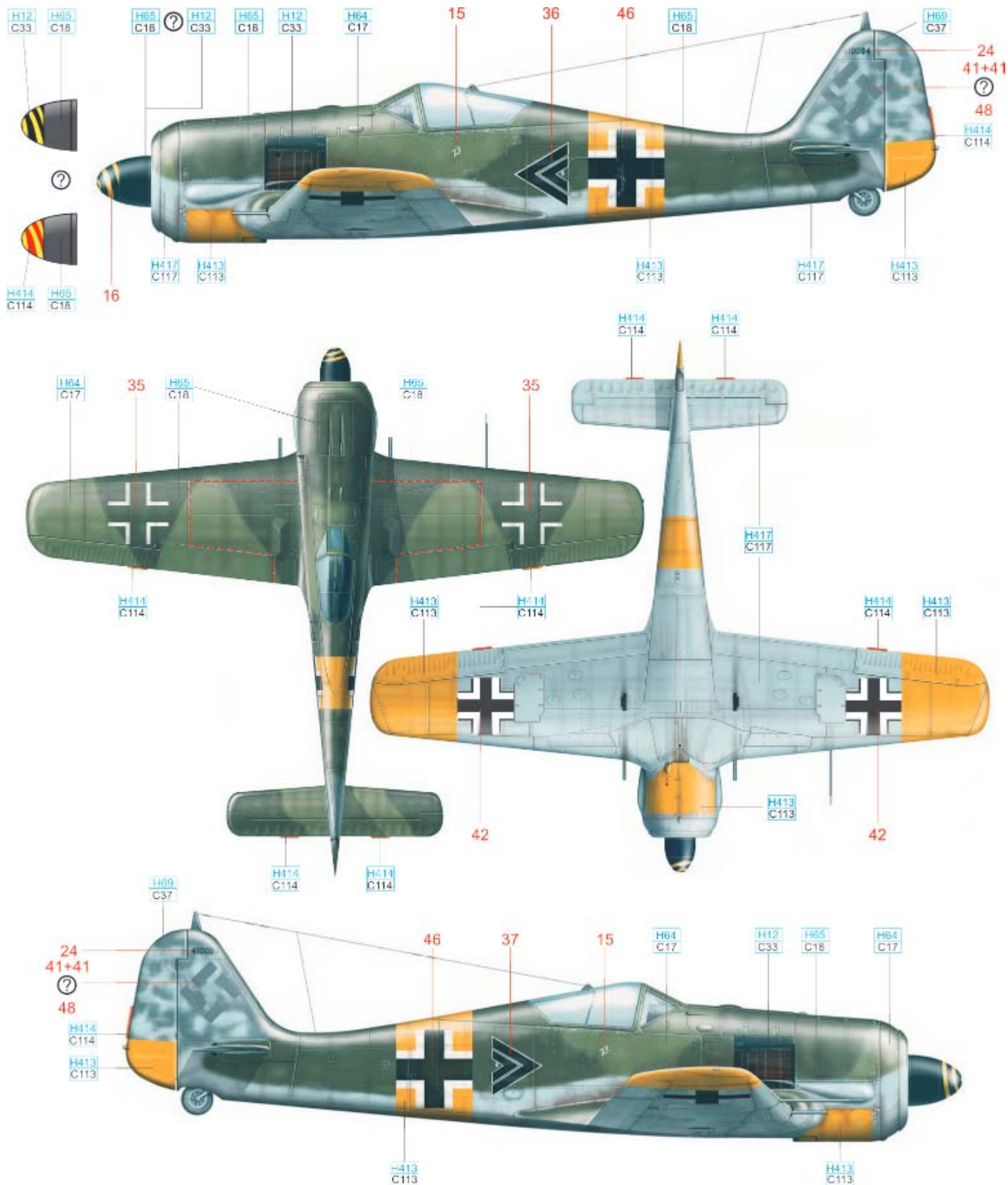

RLM 23	H414 C114	RLM 04	H413 C113	BLACK	H12 C33
RLM 76	H417 C117	RLM 75	H69 C37	RLM 70	H65 C18
				RLM 71	H64 C17

C W.Nr. 410055, Uffz. Bernhard Kunze, 2./JG 1, The Netherlands, October 1943

The black-white checker pattern appeared on aircraft flown by 1./JG 1 for a short period in 1943. As depicted, the aircraft was flown between October 4 and October 17 when Kunze achieved his sixth and seventh kills, both B-17s. Bernhard Kunze is credited with nine kills in total – seven B-17s, one P-47 and one B-24. He died on January 5, 1944 when downed by friendly AA fire during a combat mission against US four-engined bombers...just three days prior to his son's birth.

ČESKOU VERZI TEXTU NALEZNETE NA
www.eduard.com/s/70116

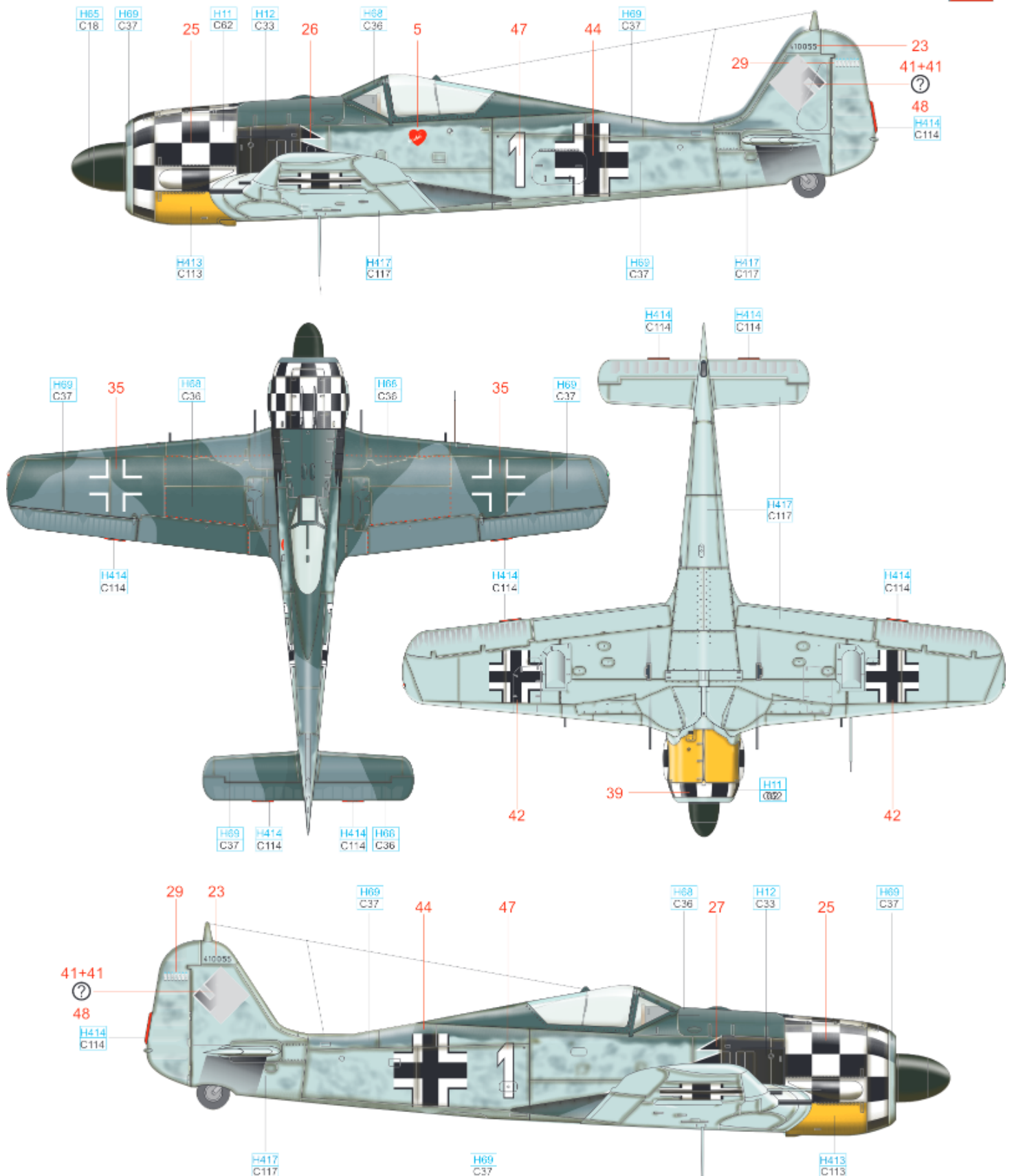

RLM 23	H414 C114	WHITE	H11 C62	RLM 04	H413 C113	BLACK	H12 C33
RLM 76	H417 C117	RLM 75	H69 C37	RLM 74	H68 C36	RLM 70	H65 C18

D W.Nr. 7328, Hptm. Dietrich Wickop, CO of II./JG 1, Woensdrecht, The Netherlands, May 1943

Dietrich Wickop led the II. Gruppe of JG 1 for roughly a month, from April 17, 1943 until his death on May 16. He is credited with 13 kills. On May 3, 1943, he took part in a combat mission against RNZAF No. 487 Squadron Venturas that hit a power station in Amsterdam. All but one were downed and Wickop himself destroyed two Venturas. The personal marking – a bird – was based on a similar marking used by Max Buchholz. Tatzelwurm, depicting a mythical alpine creature, and on the cowl there was also the II./JG 1 crest.

ČESKOU VERZI TEXTU NALEZNETE NA www.eduard.com/s/70116

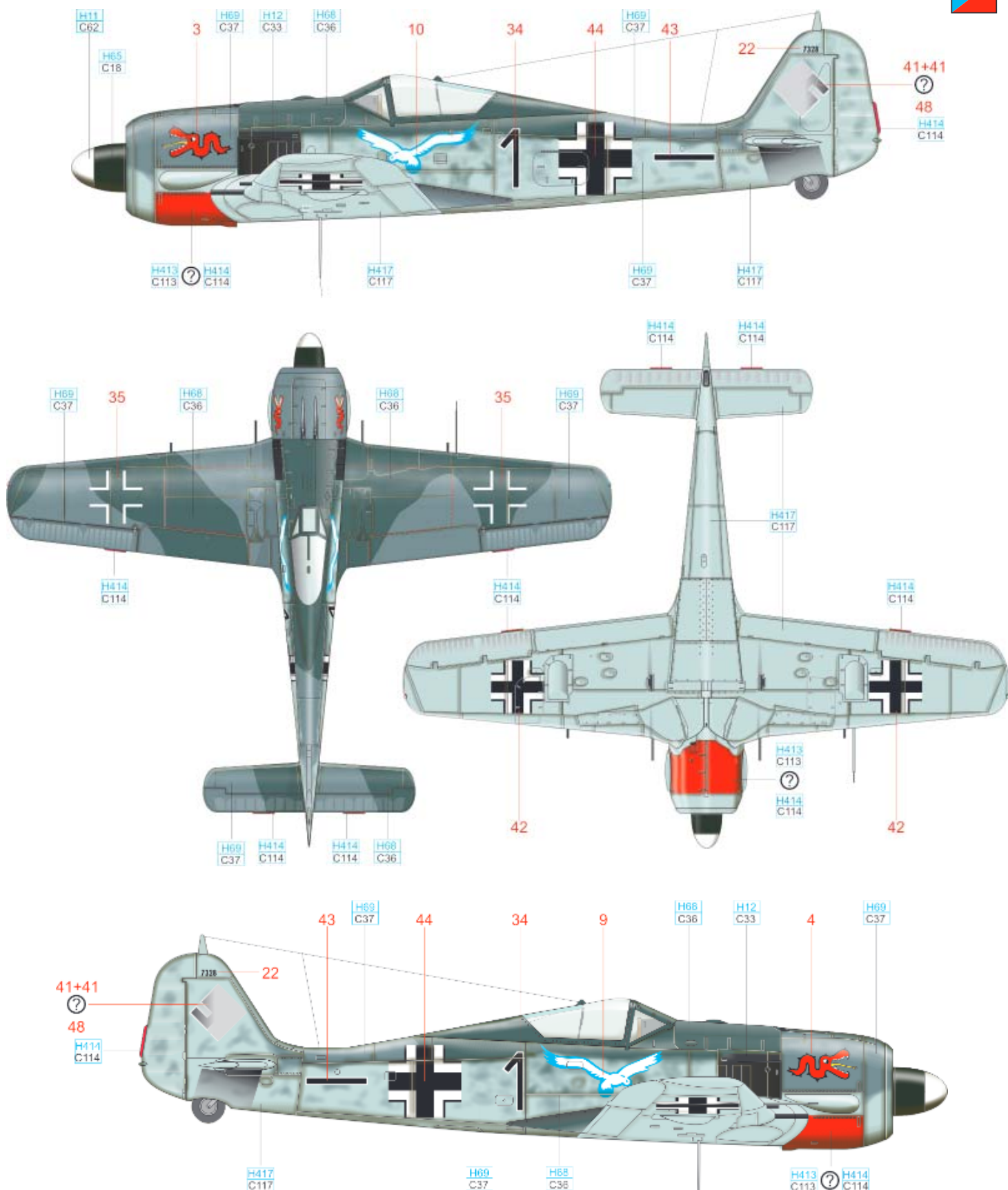

RLM 23	H414 C114	WHITE	H11 C62	BLACK	H12 C33	RLM 04	-413 C113
RLM 76	H417 C117	RLM 75	H69 C37	RLM 74	H68 C36	RLM 70	H65 C18

